



CENTURY

LIGHTING | ART | DESIGN

joekrauslighting 

301-537-5808

joe@joekrauslighting.com

www.joekrauslighting.com

Ocean Towers 2

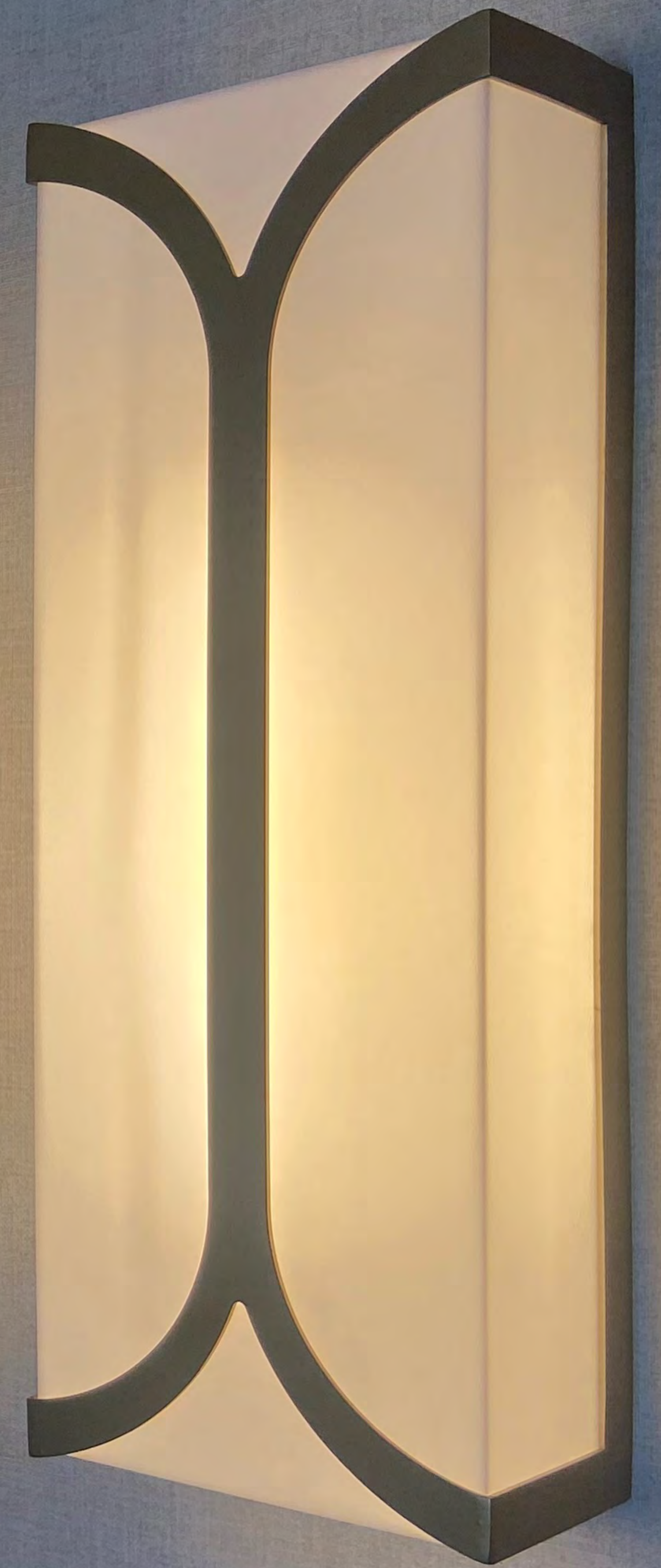

NOTES:
 1) METAL: ALL EXPOSED METAL FINISH TO BE "ENGLISH BRONZE".
 2) SHADES: "GLOSSY WHITE ACRYLIC".
 3) SOCKETS: 1x EDISON BASE MED.120V.A.C, 50-60Hz, COMPATIBLE w/E26 T10-300MM L MAX.10W LED 2700K. DIMMABLE, HARDWIRED. (Bulb not included)
 UL/CUL APPROVED

*APPROX MAX. WEIGHTS: 10LBS

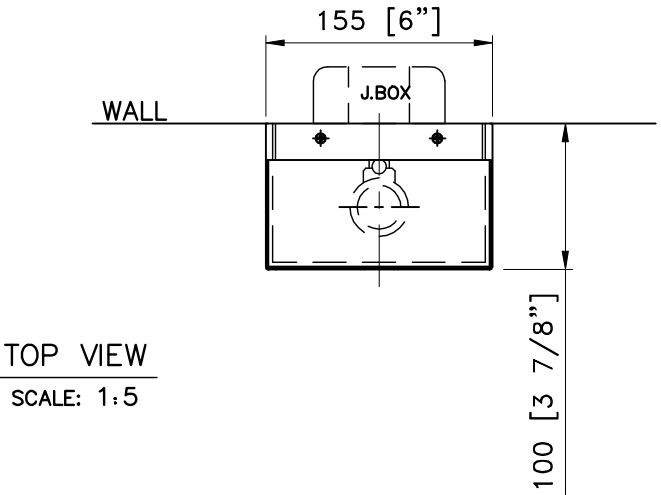

TOP VIEW
 SCALE: 1:5

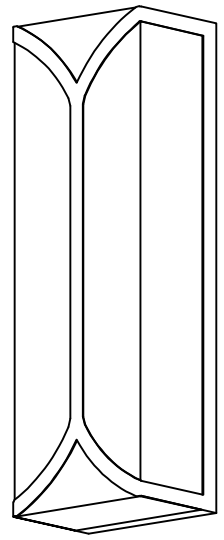

3D VIEW

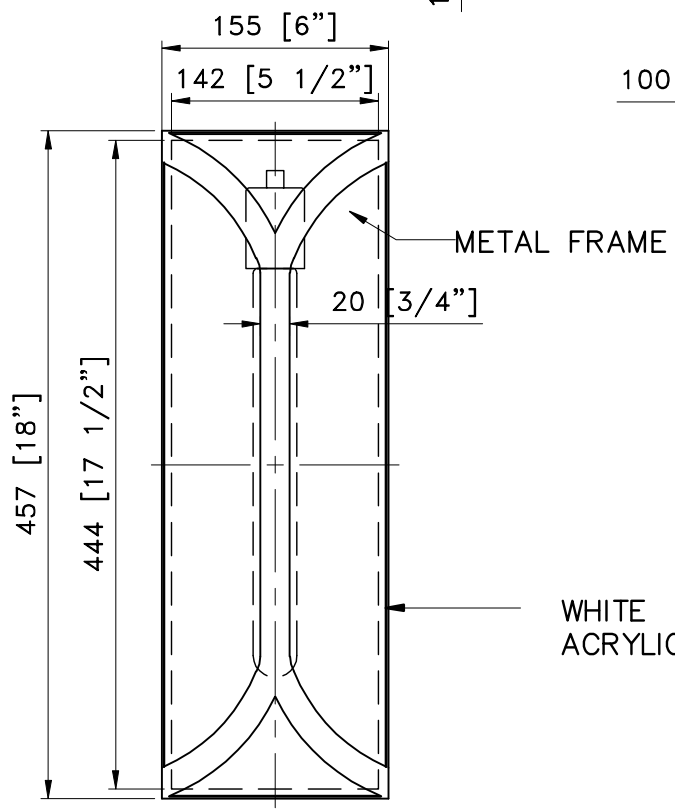

FRONT VIEW
 SCALE: 1:5

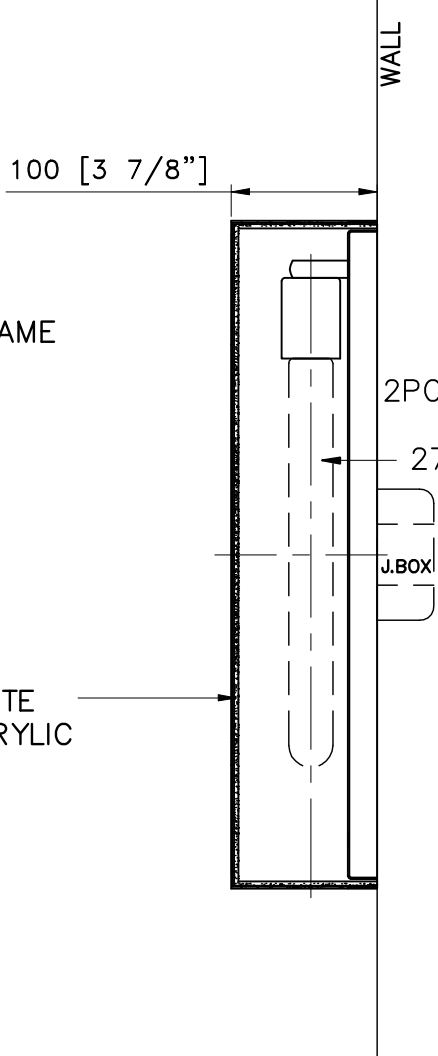

SIDE VIEW
 SCALE: 1:5

Sconce @ Barcart

ITEM NO: SU-LT-217 QTY: 150PCS

OCEAN TOWER-2

ATLANTIC CITY, NJ.

Approval: Date: _____
 With comments: _____

 Signed By: _____

Les Industries CENTURY Industries Inc.
 5645 Royalmount Ave. Dwg.#
 Montreal, Quebec, Canada H4P 2P9
 Tel: 514-842-3933 Fax: 514-842-7481
 Toll free Canada only: 1-877-842-3934

Estimated Leads time are contingent upon receiving approved submittals and are subject to change

Date: 2021/03/25 Rev: 2021/05/17
 (yyyy/mm/dd) (yyyy/mm/dd)

P1/1